

SELECTION CRITERIA FOR SEAM CENTER GUIDANCES

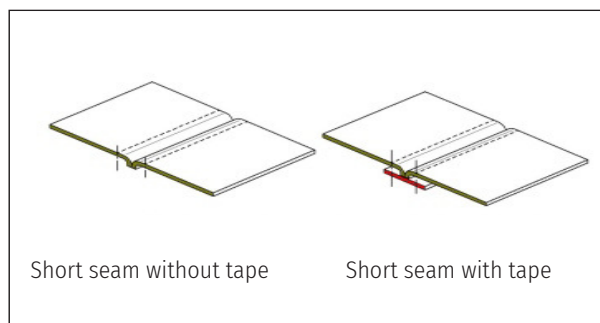
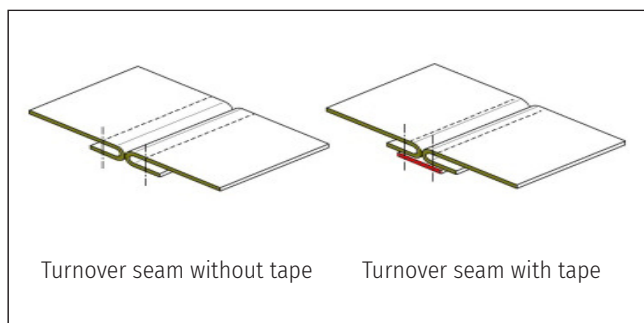

In order to compile a quote for a MK seam center guide, we require the following details:

1.) Machine make:

2.) Machine class:

3.) Needle distance:

4.) short Seam: yes
 no

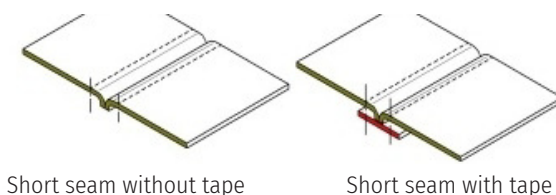

a = short seam width = material thickness:
 b = seam stub height = edge trimmer distance:

..... mm
 mm

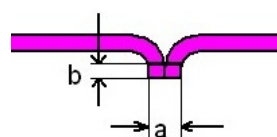

4.) turnover seam: yes
 no

